



SFT 100

**PULLAWAY**  
**SERIE 54»21**

SFT 200



Serie

**BREAKAWAY - PULLAWAY 54»21**

Per chi vuole la massima sicurezza in caso di partenza accidentale del veicolo con la pistola inserita nella presa di carico della vettura.

**PULLAWAY 54»21(ricollegabile)** sconnette la pistola e il tubo dal distributore stradale di gpl, interrompendo immediatamente il flusso di carburante.

La serie **SFT 100/200 Breakaway** funziona con rottura del canotto che dà modo alle valvole di sicurezza di attivarsi impedendo al gas di uscire. I canotti sono costruiti con diverse tarature (breaking point) per garantire la massima sicurezza di utilizzo.

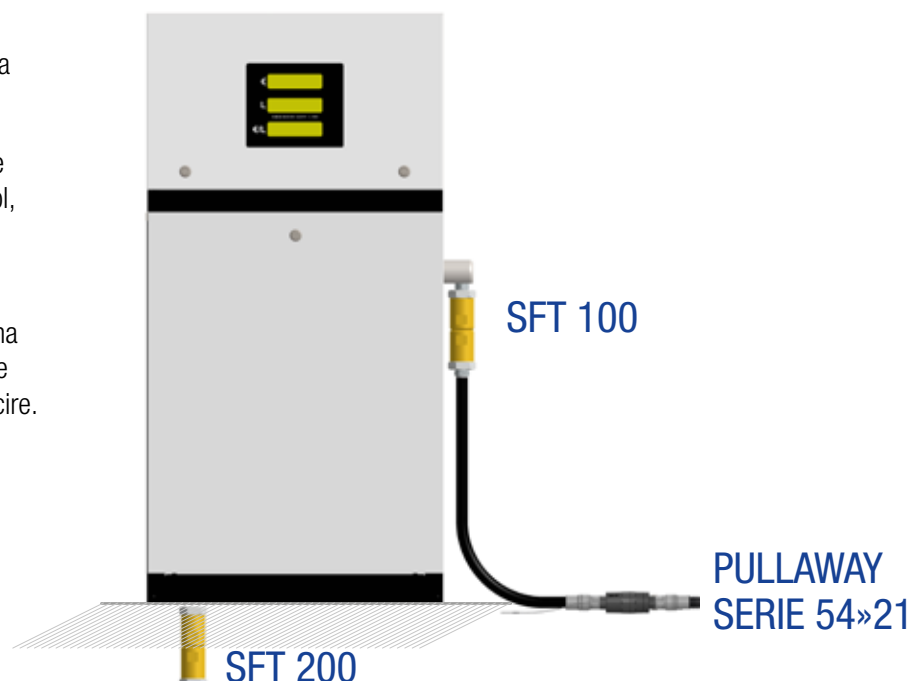

**Tutti i nostri prodotti  
sono certificati ATEX.**

Codice	Q.tà	Articolo	Materiale
SFT 0102	2	Corpo Valvola 3/4 Gas Serie SFT	Acciaio
SFT 0103	2	Guida Valvola Serie SFT	Ottone
SFT 0104	2	Valvola Serie SFT	Acciaio
SFT 0105	2	Molla Valvola Serie SFT	Acciaio
SFT 0106	2	Corpo Valvola NPT Serie SFT	Acciaio
SFT 0107	1	Canotto Ottone 8.1 Serie SFT	Ottone
SFT 0201	2	O-Ring Guida Serie SFT	Nbr
SFT 0202	2	Seeger Serie SFT	Acciaio
SFT 0203	2	O-Ring Corpo Serie SFT	Nbr
SFT 0401	1	Canotto Ottone 13.1 Serie SFT	Ottone



# Serie BREAKAWAY - PULLAWAY 54»21

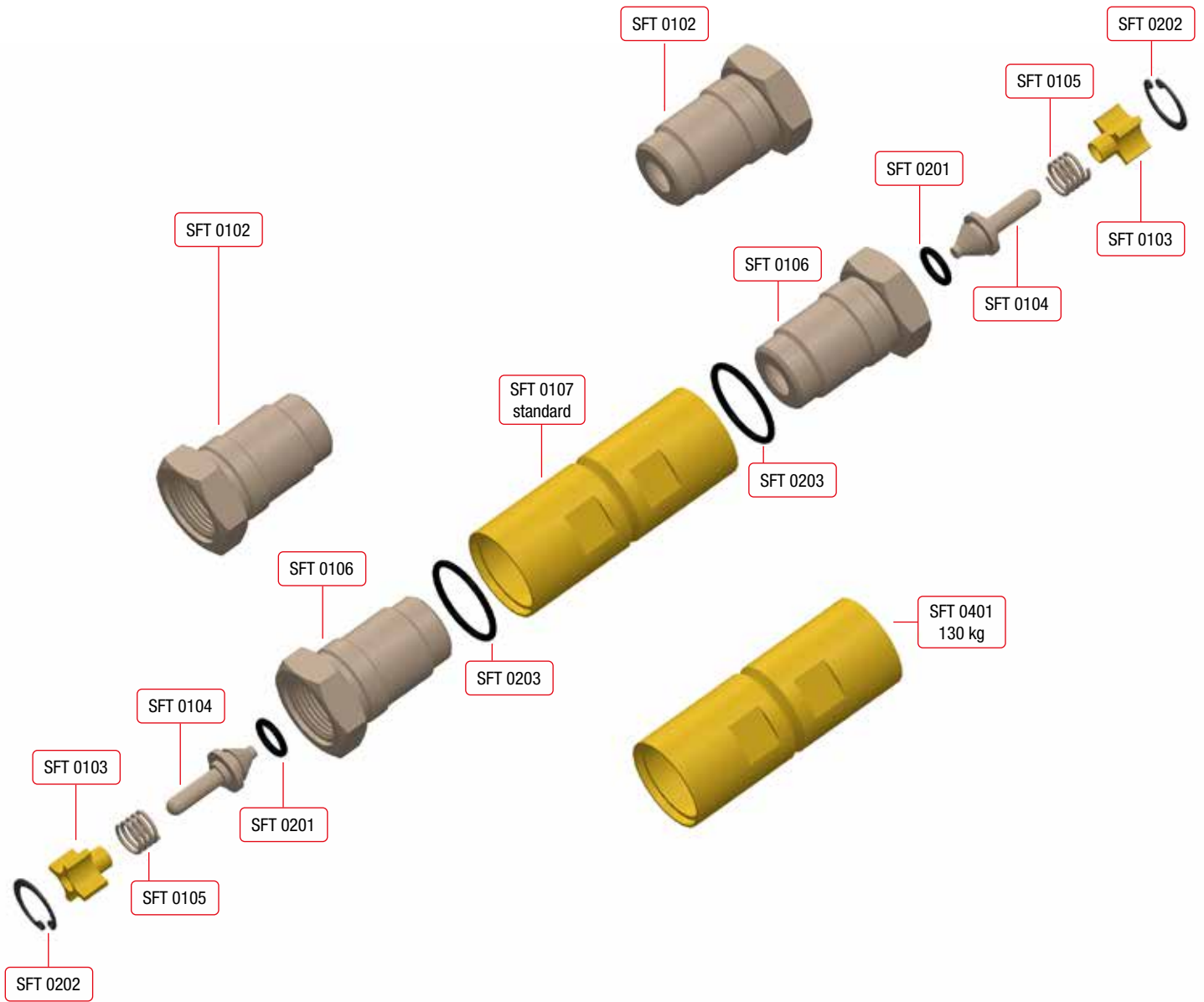

## ISTRUZIONI DI ASSEMBLAGGIO

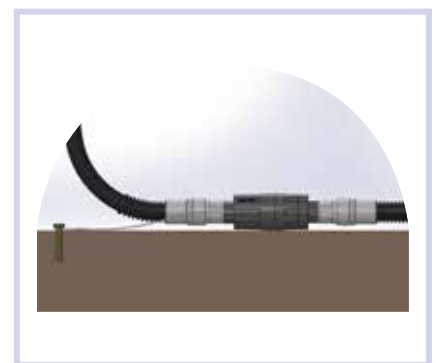
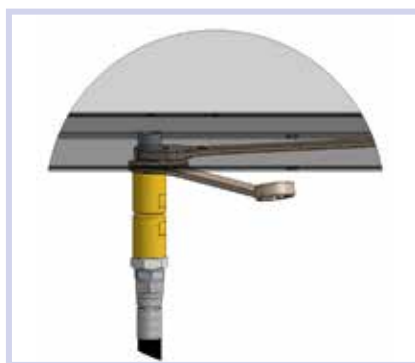
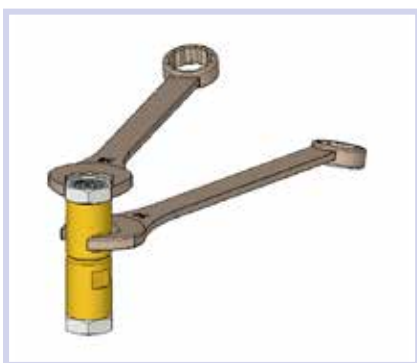

# SFT 100

# SFT CONFIGURATORE

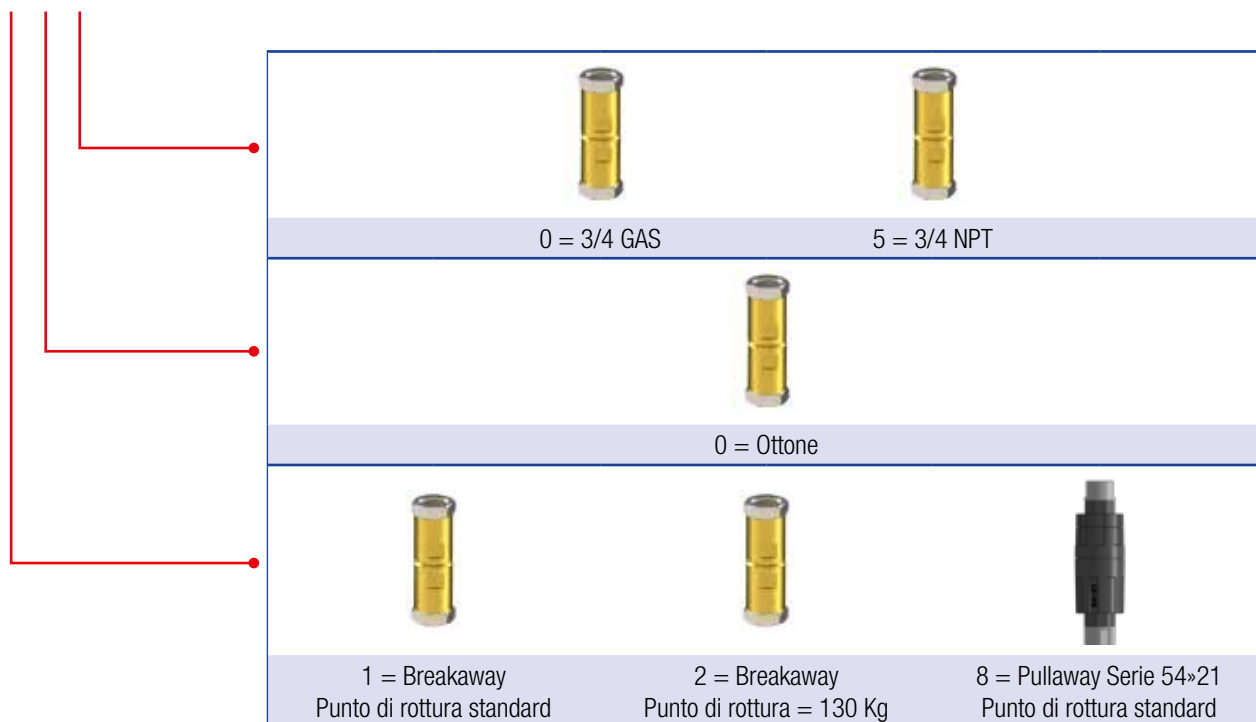

BREAKAWAY  
MODELLO SFT 100



PULLAWAY  
SERIE 54\*21

## PUNTO DI ROTTURA (BREAKAWAY POINT)

